

ROCKWELL-COLLINS

# KWM-380

Owner's Manual



**Pro-mark**<sup>TM</sup>  
*The Mark of the Professional*

523-0769877-001217  
1 October 1979

---

**owner's manual**

---

**Collins KWM-380  
Transceiver**

---

**Collins Telecommunications  
Products Division  
Electronic Systems Group  
Rockwell International  
Cedar Rapids, Iowa 52406**

---

*Printed in the United States of America*

## introduction

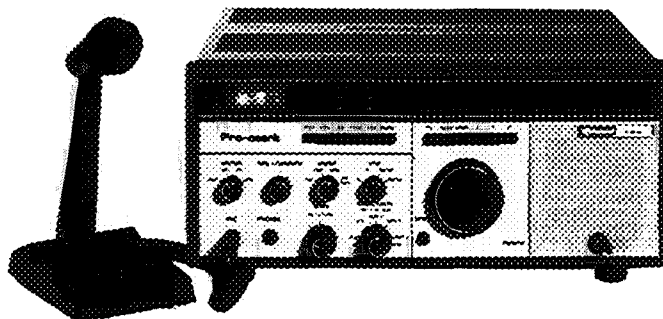

TPA-1669-017

This manual contains operating and installation information for the fully synthesized, all solid-state KWM-380 Transceiver. Full coverage from 29.999 99 down to 0.500 00 MHz is standard in the receiver circuits. Transmission is limited to 1.800 to 2.000, 3.500 to 4.000, 7.000 to 7.300, 14.000 to 14.350, 21.000 to 21.450, and 28.000 to 29.700 MHz in the Amateur Radio Service bands. The pll synthesizer tunes in 10-Hz increments either manually or with an optional remote keypad control. Split vfo is standard, as is the digital frequency display driven directly by the microprocessor.

Because of the uniqueness of each individual station, the installation information found here is limited in scope. In-depth information can be found in numerous publications commonly referred to by amateur radio operators.

Test procedures in this manual require only simple test equipment to perform. The procedures are a guide in tracing malfunctions to a functionally related group of circuit cards. Detailed tests requiring laboratory-type test equipment and schematic diagrams are included in the KWM-380 Transceiver Service Manual, Collins publication number 523-0769878.

## specifications

### Physical

Size .....	394 mm (15.5 in) wide, 165 mm (6.5 in) high, (does not include 25 mm (1 in) feet normally attached), 457 mm (18.0 in) deep
Weight .....	21.8 kg (48 lbs) max
Primary power .....	Strappable for: 105, 115, 125/210, 220, 230, 240, 250 V $\pm$ 5%, 50 to 60 Hz; or 12 to 15 V dc. 120 W max in receive; 600 W max in transmit

### Receiver

Frequency .....	0.5 to 30.0 MHz, tunable in 10-Hz steps
Modes .....	USB, LSB, AM, and CW
Sensitivity .....	0.5 $\mu$ V or better for 10 dB (s+n)/n, 2.0 to 30.0 MHz; reduced sensitivity for 0.5 to 2.0 MHz (broadcast band attenuation nominally 30 dB)
Selectivity (3-dB bandwidth) .....	Selectable
	8 kHz            *1.7 kHz
	*6 kHz           *400 Hz
	2.1 kHz          *200 Hz
If and image rejection .....	Greater than 60 dB

---

\*Optional filters

Intermodulation distortion .....	-50 dB or better for two signals of -10 dB mW each, 20 kHz apart
AGC .....	Audio output variation not more than 8 dB for 2- $\mu$ V to 100-mV open circuit rf input variation
Audio output .....	Not less than 3.5 W into 4-ohm load, at 1 kHz, at not more than 10% total harmonic distortion  Line audio output: -10 dB mW nominal into 600 ohms  Frequency response: 300 to 2400 Hz with not more than 5 dB variation
Transmitter	
Frequency .....	160- through 10-m amateur bands, tunable in 10-Hz steps  160 m     1.800 - 2.000 MHz 80/75 m   3.500 - 4.000 MHz 40 m     7.000 - 7.300 MHz 20 m     14.000 - 14.350 MHz 15 m     21.000 - 21.450 MHz 10 m     28.000 - 29.700 MHz
Modes .....	USB, LSB, and CW
Output power .....	100 W pep, nominal  In CW or RTTY, automatic turn-down to 50 W after 10 seconds, 50 percent duty cycle, key down 15 minutes, max.  With optional blower kit installed, power is 100 W average, 50 percent duty cycle, key down 1 hour, max, at 25 °C; 30 minutes, max, at 50 °C for all modes.

Unwanted signal suppression

Carrier ..... -50 dB or better

Undesired sideband,  
1-kHz ref ..... -55 dB or better

Harmonics (all) ..... -40 dB or better

Mixer products ..... -55 dB or better

Third order distortion ..... 25 dB below each tone of two-tone test

Synthesizer accuracy

and stability ..... Accuracy within  $\pm 5$  kHz after 10 minutes warm-up when 39.6- and 455-MHz oscillators are set to within  $\pm 3$  Hz

Stability within  $\pm 150$  Hz over temperature range of 0 to 50 °C

Rf load ..... 50 ohms, nonreactive. Full power output with vswr of 2:1 or less. Automatic power output turndown with vswr greater than 2:1.

Audio inputs

Microphone ..... Low impedance, dynamic; *internal strapping for high impedance*

Line ..... 600 ohm, unbalanced; 40-mV input sufficient for full rf power output

## **INSTALLATION**

### **unpacking**

The KWM-380 is shipped in two separate cartons. One contains the power transformer, the other contains the transceiver. After carefully unpacking the cartons, check to be sure no shipping damage is evident. Should any damage be apparent, save the cartons and notify the delivery carrier immediately to file claim for damage.

### **power transformer installation**

To eliminate the possibility of the power transformer breaking loose from the chassis and causing further damage during shipment, it is packaged separately. The transformer is quickly installed in five steps with just a 3/8-in open-end wrench, no 12 (3/8-in) nutdriver, and a Phillips screwdriver.

- Using the screwdriver, remove four screws from the bottom of the transceiver (near the rubber feet at each corner) and slide the dust cover off over the heat sink.
- Remove the front one of the two Phillips-head screws securing the front panel braces to the sides of the chassis and tilt the panel forward.
- Turn the transformer so terminals 1 through 8 face the front panel. With the nutdriver, remove the four nuts and lockwashers from the chassis mounting studs in the right front corner of the chassis and set the transformer over the studs.
- Using the wrench and nutdriver, secure the transformer to the studs with the four lockwashers and nuts.
- Electrically connect the transformer to the transceiver with the two attached polarized connectors. Reattach the front panel, then replace the dust cover.

Figure 1 shows the transformer properly mounted.

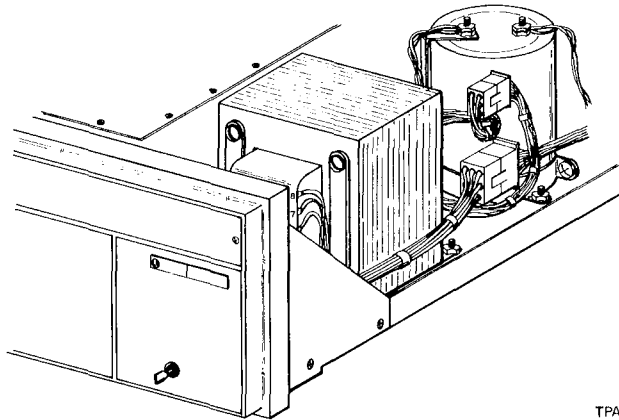

TPA-1655-011

*Power Transformer Installation  
Figure 1*

## primary power requirements

### **WARNING**

DO NOT ATTEMPT TO CHANGE VOLTAGE STRAPPING WHILE PRIMARY POWER IS APPLIED. ELECTRICAL SHOCK WILL OCCUR. DISCONNECT THE PRIMARY POWER CABLE FROM THE POWER SOURCE OR THE UNIT FIRST.

## ac voltage operation

The KWM-380 will operate from various 50- to 60-Hz voltages, depending on the following internal strapping connections.

For input voltages listed, strap TB1 as follows:

WIRE	105	115	125	210	220	230	240	250
BLACK	7	7	7	6	6	5	5	4
YELLOW	3	2	1	3	2	2	1	1
RED	6	5	4	3	2	2	1	1



Determine the average ac voltage at the primary power outlet where the transceiver is to be used. Remove the chassis dust cover and locate the protective cover plate near the left rear corner as viewed with chassis upside down. Remove the cover plate and refer to the preceding chart to make the connections indicated for the voltage nearest the primary power outlet voltage. If the outlet voltage is approximately halfway between two voltages listed, strap TB1 for the lower voltage.

Figure 2 shows TB1 correctly strapped for 105 or 240 volts.

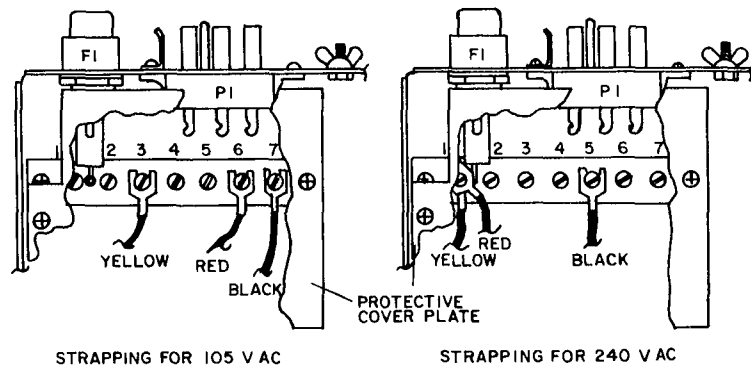

STRAPPING FOR 105 V AC

STRAPPING FOR 240 V AC

BOTTOM LEFT REAR CORNER OF TRANSCEIVER

TPA-1653-011

TB1 Strapping for 105 Volts or 240 Volts

Figure 2

### dc voltage operation

The KWM-380 will also accept 12 to 15 volts dc for backup emergency power. The primary power connector must be strapped as shown in figure 3. Power requirements are nominally 3 A in receive and 20 A in transmit.

REAR (WIRING SIDE) VIEW OF CABLE CONNECTOR

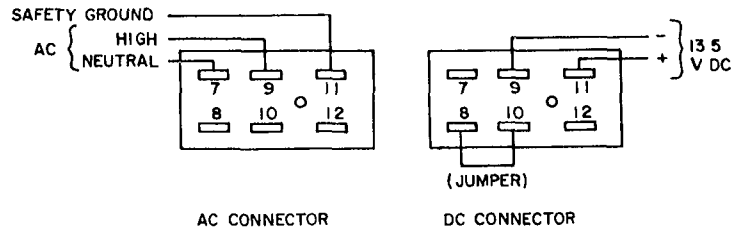

AC CONNECTOR

DC CONNECTOR

TPA-1654-011

Power Connector Strapping for AC or DC Operation

Figure 3

## operating location

The normal operating location should be chosen so the transceiver is away from heat vents and normal airflow around it is unobstructed. Do not lay objects on top or against the sides. It is especially important that the heat sink have a free flow of air about it. An automatic turndown circuit will reduce the rf output power if the heat sink overheats. This is for self-protection of the power amplifier final output stages.

The AC-2808 Blower Kit is available for attaching to the heat sink. This blower supplies cooling air to permit normal operation in close quarters or high-duty cycle operation.

## system interconnections

Figures 4 and 5 show typical hookups. Table 1 lists the signal parameters for all front and rear connectors except the primary power and rf input/output.

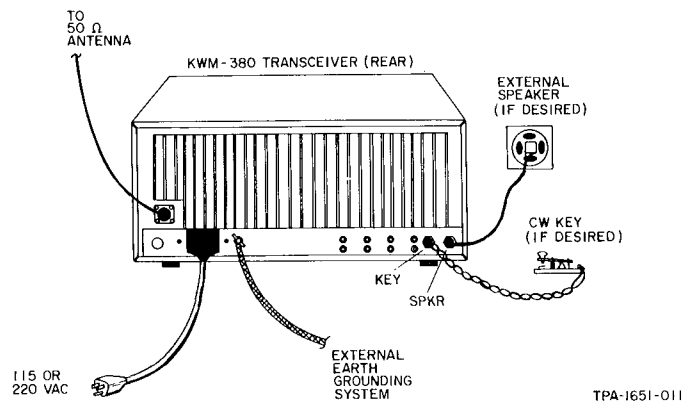

*Transceiver Installation Connections  
Figure 4*

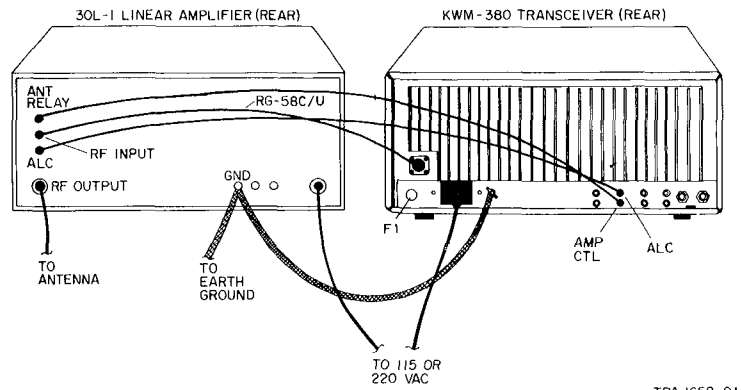

*Transceiver and Linear Power Amplifier Installation Connections  
Figure 5*

*Table 1 Connector Signal Parameters*

CONNECTOR	SIGNAL PARAMETER
Microphone (mates with PJ-068)	Tip—ptt line; ground to transmit Ring—microphone audio; low-impedance input (270 $\Omega$ ), approx 5 mV in for full power output Barrel—common ground
Headphones (mates with PJ-055)	Tip—receiver audio; 4- to 8- $\Omega$ impedance, up to 4-W output Barrel—ground
External SPKR (mates with PJ-055)	Tip—receiver audio; 4- to 8- $\Omega$ impedance, up to 4-W output Barrel—ground
CW KEY (mates with PJ-055)	Tip—keying line; ground to transmit Barrel—ground
J2 Line audio in (mates with phono plug)	600 $\Omega$ , unbalanced; 40-mV input produces 100-W rf output

Table 1 Connector Signal Parameters (Cont)

CONNECTOR	SIGNAL PARAMETER
J3 ALC (mates with phono plug)	Input for negative ALC voltage from external power amplifier
J4 Antenna relay (mates with phono plug)	External access to receiver contacts of internal antenna transfer relay. Internally jumpered to J8. (Cut jumper if used.)
J5 Transverter (mates with phono plug)	Approximately 200-mW (100-mW, min) output from exciter into 50-ohm load. (To obtain output, connect this line to dc ground through a 1-mH rf choke.)
J6 Line audio out (mates with phono plug)	600 $\Omega$ , unbalanced; -10 dB mW at AGC threshold. Level is independent of audio gain control.
J7 Ampl control (mates with phono plug)	Normally open relay contacts; contacts grounded in transmit. 2 A, 28 V dc or 0.75 A, 115 V ac capacity.
J8 Rcvr antenna input (mates with phono plug)	Direct input to receiver front end. Bypasses transmit low-pass filters and antenna transfer relay. Internally jumpered to J4. (Cut jumper if used.)
J9 Push-to-talk (mates with phono plug)	Ground to place transceiver in transmit (Line is connected to +5 V through 10-k $\Omega$ resistor.)

## grounding

The importance of a good ground system cannot be overemphasized. All units of the system should have ground interconnections through heavy wire (#12 AWG or larger) or ground strap (6-mm (1/4-in) wide or larger) between ground lugs. Use as short a length of ground wire or braid as practical between units or external ground.

Connect the KWM-380 ground lug on the rear to a good earth or water-pipe ground.

Before using a water-pipe ground, check to make sure that no plastic, rubber, or other such insulating sections will interrupt

the electrical continuity to ground. Install a jumper around any insulating sections found. Use heavy copper wire or ground braid and metal pipe clamps.

## **antennas**

The antenna is one of the most important parts in the performance of any radio communications system. System performance is directly related to the efficiency of the antenna. Because each individual installation has unique characteristics, various types of antennas, their characteristics, and installation information cannot be covered in this manual. A number of excellent reference works on antennas are available.

The KWM-380 is designed to operate into a nonreactive rf load of 50 ohms. Impedance mismatches producing vswr's lower than 2:1 are acceptable. For vswr's 2:1 or greater, the transceiver power amplifier output is automatically reduced in proportion to the reflected power.

## OPERATION

### introduction

Controls on the KWM-380 have been labeled so that their function is self-explanatory. After referring to figures 6 and 7 and tables 2 and 3, many operators will need no further explanation. The following paragraphs summarize operation of several of the controls and give check lists for initial control settings for each operating mode.

### frequency selection

The large tuning knob and row of switches immediately above it control the transceiver frequency selection. When power is applied to the transceiver, the frequency is automatically set to 15.000 00 MHz. Frequency data is not retained in the vfo registers when power is turned off.

There is no need for a band-switch since selection of the MHz tuning increment permits tuning from 0 to 29 MHz in 1-1/2 turns of the knob. This rate is effective for the MHz digits only. Selecting other increments automatically switches the tuning rate to 200 steps per turn. For example, selecting the 100-Hz increment gives 20 kHz per revolution of the tuning knob.



When a switch is depressed to select a frequency increment to be changed, that and all higher increments will change as the tuning knob rotates. For example, if the 100-Hz increment is selected, the 10-Hz digit remains where last set. Rotating the tuning knob clockwise causes the 100-Hz digits to increment up through 9, index the 1-kHz digit by one, and roll around to 0 to continue incrementing toward 9 again. Counterclockwise

rotation causes the frequency to decrement in a similar fashion.

Once a chosen frequency is selected, pressing the LOCK switch to the in position electronically disables the tuning knob operation. In LOCK, rotation of the tuning knob has no effect on the frequency. To restore tuning control to the knob, press the LOCK switch to return it to the out position.

The SYNC switch is momentary and when depressed, will load the displayed frequency value from the operating vfo register into the register that is not being displayed. For example, if using register B, depressing SYNC will load the same frequency into register A. The frequency in register B can then be changed without affecting the stored value in register A.

The A and B vfo registers may contain any two frequencies. Split-frequency operation is achieved by selecting RA-TB or RB-TA. With RA-TB chosen, the transceiver will receive on the frequency in the A register and transmit on the frequency in the B register. The frequency display shows the receive frequency when receiving and the transmit frequency when transmitting.

The vfo's can be set up for split-frequency operation on any two frequencies, even within separate bands.

In CW operation, the SPOT switch enables an 800-Hz tone that is applied to the receiver audio output. By tuning the received signal so the CW audio frequency matches the 800-Hz SPOT frequency, the receiver frequency will be matched with the transmitted frequency.

Table 2 Front Panel Controls and Indicators

ITEM	FUNCTION
METER (switch)	Selects signal applied to meter during transmit
ALC	Transmitter automatic level control voltage
VC	Collector voltage for final amplifier stage
PF	Forward rf power sampled at amplifier output

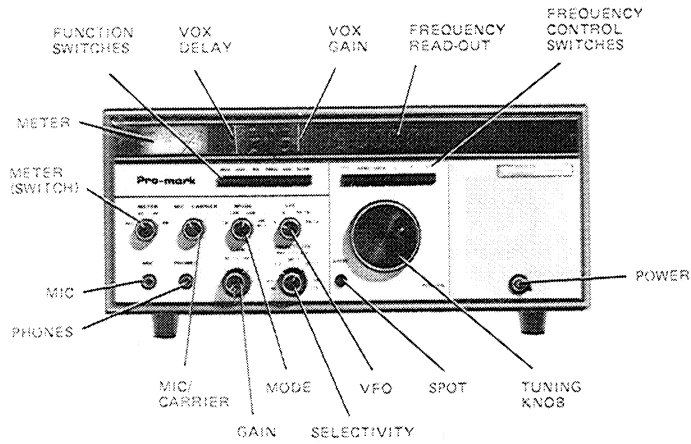

TPA 1649-017

*Front Panel Controls and Indicators  
Figure 6*

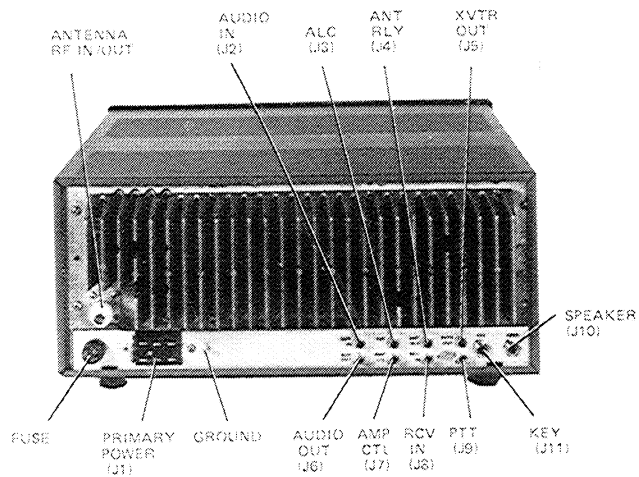

TPA-1650-017

*Rear Panel Connectors  
Figure 7*



Table 2 Front Panel Controls and Indicators (Cont)

ITEM	FUNCTION
BW (large knob)	Selects filter bandwidth.
8 0	8 0-kHz filter (for AM, also selects optional 6-kHz AM filter if installed)
2 2	2.2-kHz filter (for normal SSB).
OPT 1, 2, 3	Three positions for optional filters.
MODE	Selects mode of transmit operation
CW	Continuous wave.
USB	Upper sideband. } Receive sideband determined by
LSB	Lower sideband. } setting of PBT control
AM RCV	Amplitude modulation in receive only. Transmitter does not operate in AM mode
GAIN	Adjusts gain of receiver circuits
AF (small knob)	Af amplifier gain.
RF (large knob)	Rf amplifier gain.
MIC/CARRIER	In sideband operation adjusts microphone amplifier gain In CW operation adjusts rf carrier level.
PHONES	Output jack for low-impedance (4- to 8- $\Omega$ ) headphones. Connecting phones inhibits speaker and SPKR (on rear panel) outputs.
MIC	Input jack for low-impedance, dynamic microphone Jack is also wired for ptt signal.

Table 3 Rear Panel Connectors

ITEM	FUNCTION
Antenna	Rf connector (type S0-239) for coaxial cable connection to antenna coupler
Fuse	Primary power fuse (8 A for 110 V, 4 A for 220 V)
J1	Primary power connector.
Ground	Stud for earth-ground connection.
AUD IN (J2)	Input for 600-ohm, unbalanced line audio.
ALC (J3)	Negative ALC input signal from external power amplifier
ANT RLY (J4)	Receive contacts of internal antenna transfer relay (Jumpered to RCV IN (J8) if separate receive antenna not used.)
XVTR OUT (J5)	Exciter output signal for use with transmitting converter
AUD OUT (J6)	Output for 600-ohm, unbalanced line audio.
AMP CTL (J7)	Relay contacts for tr-switching external power amplifier. (Contacts grounded in transmit mode.)
RCV IN (J8)	Receiver front end signal input. Bypasses antenna transfer relay and transmit low-pass filters. (Jumpered to ANT RLY (J4) if separate receive antenna not used.)
PTT (J9)	Push-to-talk switch input Ground to command transmit operation.
KEY (J10)	CW key input.
SPKR (J11)	Output for 4- to 8-ohm speaker. Disconnects internal speaker when external speaker connected. (Inhibited when headphones connected to PHONES jack on front panel.)

## function switches

Depressing the MOX or VOX switch selects manual- or voice-operated keying, respectively. The rear panel PTT jack (J9), when grounded, will key the transmitter regardless of MOX or VOX selection.

When pressed to the in position, the MOX switch keeps the transceiver continuously keyed. For normal transmit-receive operation, the MOX switch must be out. With MOX and VOX both out, the transceiver is keyed with the microphone ptt switch. Selecting VOX enables voice keying in sideband or CW keying in CW.

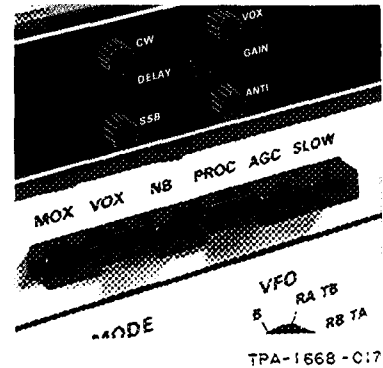

The AGC function can be enabled by depressing the AGC switch. The out position inhibits AGC operation. Release time of the AGC is controlled by the SLOW switch. The in position selects a slow release time. This is normally used in SSB operation. Fast AGC release, the switch out position, is more useful for CW reception.

The optional noise blanker and speech processor circuits, when installed, are selected by depressing the respective NB or PROC switch to the in position. The noise blanker reduces or eliminates pulse-type noise, such as from automobile ignition systems, from the receiver audio output. The speech processor increases the ratio of average to peak power in the rf output signal. This increases talk power and may be desired in DX operation.

The DELAY controls adjust the time the transceiver is held in the transmit mode after the voice input or CW keying signal is removed. Clockwise adjustment of either control increases the delay between the last input and automatic transmit-to-receive switching. Independently set these controls as desired for the preferred delay times.

The GAIN controls adjust the sensitivity to microphone input signals from the operator (VOX) or from the receiver speaker (ANTI-VOX). Set the VOX GAIN so the normal voice level used during transmitting keeps the transceiver keyed. A level too high may cause background noises to key the transmitter while a level too low will require a loud voice input to the microphone for keying. Set the ANTI-VOX GAIN to a level that prevents the microphone pickup of the speaker output from tripping the VOX circuit.

## selectivity

The large (rear) BW switch controls the receive bandwidth by selecting any one of the installed filters.

The small (front) PBT control positions the passband of the selected filter within the 10-kHz passband of the receiver first if and is used to select the desired sideband in receive. For LSB, position the pointer to near 2.2. For USB, position the pointer to near OPT 2.

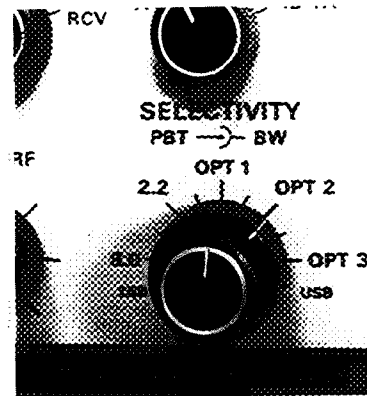

TPA-1666-0:7

**NOTE** The MODE switch does not determine which sideband is received. It only selects the desired transmit passband.

The PBT control can shift the position of the receive selectivity by adjusting the passband above or below the normal frequency position. By adjusting the PBT control toward the left of center, the filter passband is shifted to a lower frequency. Positions right of center shift the passband to a higher frequency. Figure 8 illustrates this. Figure 9 illustrates how the passband can be tuned away from an interfering signal to put the signal outside the passband and eliminate the interference.

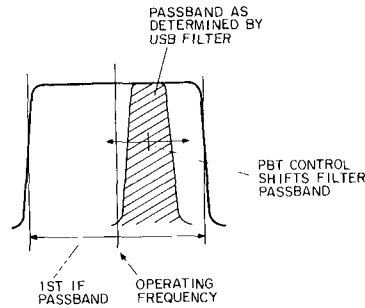

TPA-1665-011

*Filter Passband Positioning With PBT Control*  
Figure 8

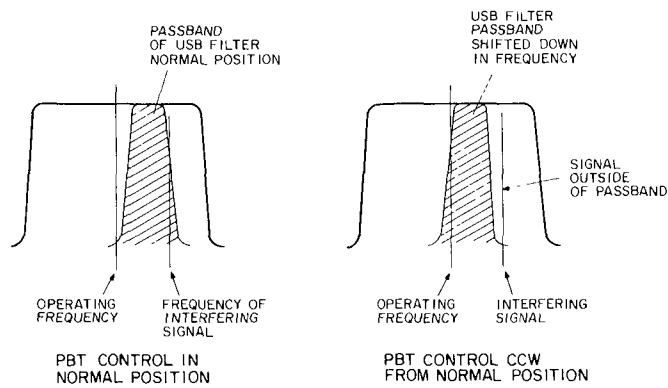

TPA-1664-011

*Passband Tuning To Eliminate Interfering Signal*  
Figure 9

## mic/carrier

The MIC/CARRIER control adjusts the audio modulation level or the CW carrier level to control the rf output power. For voice operation, set the METER switch to ALC. Key the transmitter and speak into the microphone or say "Ahhhh" in a normal operating-voice level while adjusting the MIC/CARRIER control until the meter indicates +10 to +20 dB over S9 on the S-unit scale. A more counterclockwise position of the control will give less than this full power output setting.

For CW operation, set the METER switch to PF. Key the transmitter and adjust the MIC/CARRIER control clockwise until no further increase in power is noted. A more counterclockwise position of the control will give less than this full power setting.

## **operating check lists**

Adjustments of the KWM-380 controls will vary with individual operators. The following check lists give initial control settings for each mode of operation. After setting up the transceiver, the controls may be adjusted as desired during operation.

These check lists assume that the equipment is properly installed, the microphone or CW key connected, and the DELAY and GAIN controls adjusted.

### **CW operation**

- Turn on POWER.
- Set MODE to CW.
- Select VFO A or B.
- Adjust RF and AF GAIN to desired levels.
- Select desired BW.
- Set PBT to midrange (vertical position).
- Select unused frequency near desired operating frequency.
- Set METER to PF.
- Select VOX function.

- Key transceiver and adjust MIC/CARRIER to power output level desired (normally until power does not increase with continued increase in MIC/CARRIER level).
- Release key and tune to operating frequency.

## **SSB operation**

- Turn on POWER.
- Set MODE to LSB or USB, as desired for band of operation.
- Select VFO A or B.
- Adjust RF and AF GAIN to desired levels.
- Select 2.2-kHz bw.
- Set PBT to second index mark to left (LSB) or right (USB) of top center.
- Select unused frequency near desired operating frequency.
- Set METER to ALC.
- Press in VOX function switch if ptt operation not desired.
- Key transmitter and speak into microphone while adjusting MIC/CARRIER to power output level desired (normally to level where meter indicates +10 to +20 dB over S9 on S-unit scale).
- Unkey and tune to operating frequency.

## **RTTY operation**

- Make sure microphone is disconnected.
- Turn on POWER.
- Set MODE to LSB.
- Select VFO A or B.

- Adjust RF and AF GAIN to desired levels.
- Select 2.2-kHz bw.
- Set PBT to second index mark to left of top center.
- Set METER to PF.
- Select unused frequency near desired operating frequency.
- Press in MOX function switch (transceiver keys).
- Adjust MIC/CARRIER to power output level desired (normally until power does not increase with continued increase in MIC/CARRIER level).
- Press MOX function to release to out (unkeyed) position.
- Tune to operating frequency.



## MAINTENANCE

Without extensive test equipment, only a limited amount of maintenance can be performed. The following information lists the replaceable fuses and lamps, and guides in determining general functional areas in which a detected malfunction may be located. Only a multimeter and rf voltmeter are required for the tests.

### replaceable fuses and lamps

Primary power (located on rear panel) — 8 A, AGC for 110 V; 4 A, AGC for 220 V.

13-volt supply (two fuses located on power supply card under chassis) — 2 A, AGC.

Panel meter lamps (wired into holder at top rear of meter) — T1 3/4, 14 V, 100 mA, type 7373.

### front-panel troubleshooting

INDICATION	POSSIBLE CAUSE	TROUBLESHOOT
Rapid beeping in speaker	Synthesizer unlocked	Check 5-, 9-, and 24-V supply outputs  Check synthesizer output levels.
No audio output	Receiver audio circuits malfunctioning  Synthesizer outputs weak/absent.  High loss in low-pass filters or antenna transfer relay.	Check 13-V supply fuses.  Check synthesizer output levels.  Connect receiver antenna to RCV IN jack on rear panel (Bypasses antenna transfer relay and low-pass filters )
No rf output	Power amplifier circuits malfunction.	Check for 3 V rms (at full carrier gain) at J1 on rcvr-extr board.  Check synthesizer output levels.

### **synthesizer output levels**

Refer to figure 10 for connector locations on rcvr-extr board. The following measurements are made with an rf voltmeter.

455 kHz (J10) in SSB receive — greater than 50 mV rms.

454.2 kHz (J11) in CW receive — greater than 50 mV rms.

39.6 MHz (J3) in receive or transmit — approximately 0.5 V rms.

1st mixer injection (J2) in receive or transmit — approximately 0.5 V rms.

### **receiver-exciter sidetone and spot potentiometer adjustments**

Refer to figure 10 for locations of sidetone frequency and level and spot tone level potentiometers. These potentiometers may be adjusted to the level or frequency desired by the operator.

**DO NOT MAKE ANY OTHER ADJUSTMENTS ON THE RECEIVER-EXCITER BOARD WITHOUT THE INSTRUCTIONS AND TEST EQUIPMENT SETUP GIVEN IN THE KWM-380 SERVICE MANUAL.**

### **microphone impedance selection**

The KWM-380 is factory wired for a low-impedance microphone. A high-impedance microphone may be used, however, by removing a 270-ohm resistor and replacing it with a value between 10 and 47 k $\Omega$  that approximately matches the microphone impedance. Refer to figure 10 for the resistor location. Use caution in removing and installing the resistors. Do not apply heat from the soldering iron to the circuit board pads longer than necessary. Excessive heat can damage the circuit board.

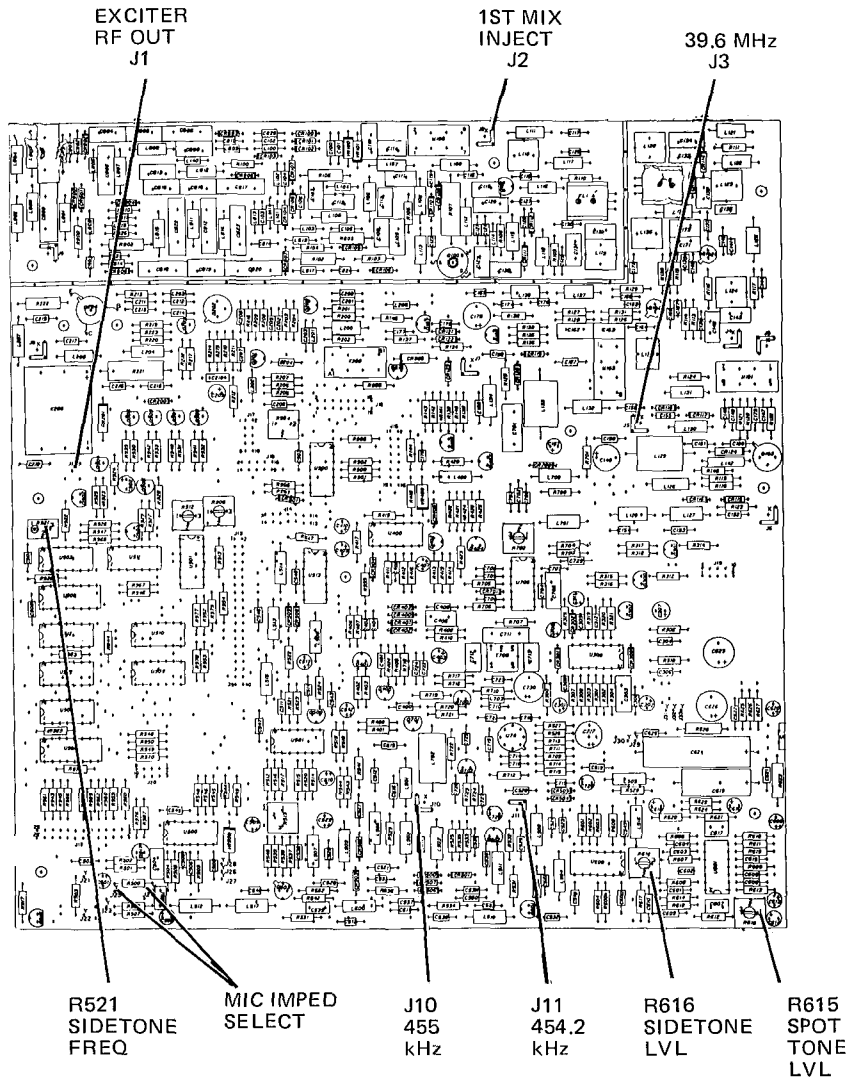

TPA-1683-019

Receiver-Exciter Connectors and Adjustments Locations  
Figure 10

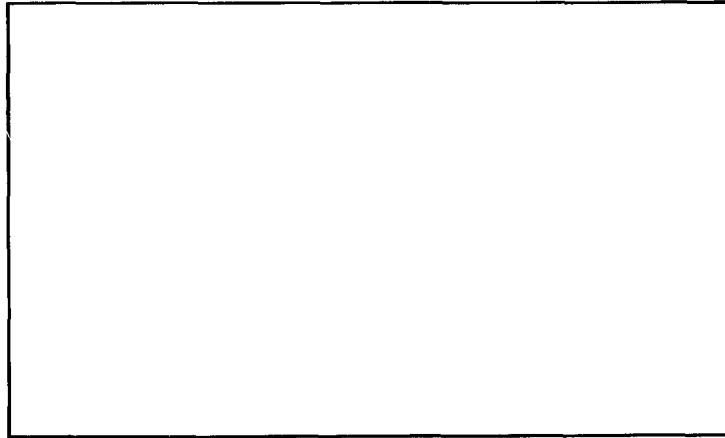

**Rockwell International**

**Collins Telecommunications  
Products Division  
Electronic Systems Group**